



KILLARK[®]



***LED TECHNOLOGY
for Harsh
and Hazardous
Environments***

NEW!
LOW WATTAGE
Vapor Tight

***Direct Replacement for
Incandescent or CFL's in
1,000's of locations***

Full Range of LED Luminaires



***MBL Series
Compact Size***



***VM1L Series
Reduced Profile***



***VM4L Series
High Wattage***



***EML Series
Explosion-Proof***



HSI = GREEN
HUBBELL SUSTAINABILITY INITIATIVE



Hubbell is committed to be a recognized leader in conserving natural resources to sustain our environment.



LED TECHNOLOGY



KILLARK® is pleased to announce LOW WATTAGE “Vapor Tight” LED labor and energy saving luminaires. Sized to replace “utility” type incandescent or CFL’s, the VSL Series provides exceptionally long life with numerous mounting options and the industry’s broadest **COLOR** globe offering for Hazardous Locations in both glass and polycarbonate. The VSL utilizes time-tested industrial grade components, and offers an upgrade path for existing installations in 1000’s of locations worldwide. Market demand for this clean white light is growing exponentially, and Killark’s VSL fits the bill for wet, corrosive and NEMA 4 locations that are classified as Class I Division 2; Class II Division 2.

Key Features and Benefits

- L70 60,500 hours life at up to 55°C (5+ years to 70% of initial output) equals Minimal Maintenance.
- LM79-08 Certified Photometrics Tested (NIST Recognized Lab)
- LM80-08 Lumen Maintenance Measurement
- Solder-LESS LED Board Connections - Vibration Resistant
- Less than 13 Watts of Power for VSL1330, less than 16 Watts for VSL1630
- Instant on - including after power interruption
- “World Voltage” 120-277VAC 50/60Hz
- Crisp white light - 5000°K (CCT);70 CRI
- Wide variety of optics, including Glass Globes, (Standard, Tempered, Color) plus polycarbonate (Clear and Color)
- Optional Mounting arrangements, including Pendant, Wall, Ceiling, Stanchion and adapters
- Copper-Free Aluminum Construction with electrostatically applied epoxy/polyester powder paint for corrosion resistance
- Traditional Industrial Appearance, Superior Performance

Coming Soon - DVL Series LED Fixture

Class II, Div. I, Groups E,F,G
Class I, Div. II, Groups A,B,C,D



INDEX

LED Green Technology Overview	IFC
Introduction to VSL Vapor Tight LED	1
Catalog Logic.....	2
Ordering Information.....	3, 4, 5
Components/Electrical Ratings/Temperature Data	6, 7
Photometrics	8, 9
Dimensions.....	10

What Makes this Product GREEN?

- Saves energy compared to other lighting sources:

Fixture Type	Light Source	Line Wattage ②	Delivered Lumens ③	Lumens per Watt	Photometric Report
VSL1330 ①	LED	12.42	1121	90.3	BAL16352
VSL1630 ①	LED	15.6	1328	84.9	BAL16350
NV2FG26 ①	CFL	26.4	1411	53.4	BAL1720
V Series 150W ①	Incan.	150.0	2699	18.0	ET442841
V Series 100W ①	Incan.	100.0	1562	15.6	ET442841④
V Series 90W ①	Incan.	90.0	1367	15.2	ET442841④
V Series 75W ①	Incan.	75.0	1122	15.0	ET442841④
V Series 60W ①	Incan.	60.0	817	13.6	ET442841④
NV2IG15 ①	Incan.	150.0	2087	13.9	BAL1716

- Saves Significant Maintenance Labor Time and \$ (fewer trips for relamping)

	Hours Life ⑤	No. Trips
Killark LED	60,500	1.0
26 W CFL	10,000	6.05
60 -- 150 Incan.	750	80.7
- Lower facility carbon footprint (emissions) by reducing electrician maintenance trips to fixture
- Service Trucks: direct diesel or gas emissions
- Forklifts: use utility electricity to charge batteries, or gas
- High Color Rendering (5000°Kelvin - CCT; 70 CRI) for better visibility can reduce the number of fixtures needed.
- The US DOE recognizes “Spectrally Enhanced Lighting”, particularly at low light levels, as a method to maintain visual effectiveness using fewer watts, e.g. vs HPS (2100°Kelvin - CCT; 21CRI) ⑥.
- Killark LED luminaires use RoHS compliant materials to minimize environmental contamination

① All calculations using Killark VCG-100 Clear Globe

② Incandescent or Driver/Ballast at 120VAC 60Hz

③ Total Zonal Lumens (Delivered vs Initial Lamp).

④ Initial lumens of the 3 major brands averaged and factored for delivered lumens at same efficiency ratio as 150W incandescent test

⑤ Minimum LED Life to 70% of initial lumen output; CFL or Incandescent from mfg. catalog data

⑥ For more information go to http://www1.eere.energy.gov/buildings/spectrally_enhanced.html



LED Technology

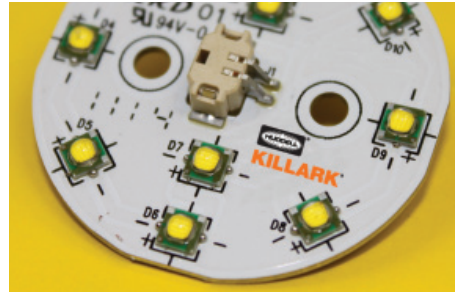

Class I, Div. 2, Groups A,B,C,D
Class I, Zone 2, Groups IIC,IIB,IIA
Class II, Div. 2, Groups F,G^①
Class III
Suitable for wet locations
Enclosure Type 4^①

 Certified - File LR11713

FEATURES-SPECIFICATIONS

V SERIES LED

Introduction

Killark 'VSL' Series LED fixtures are designed for installations where moisture, dirt, dust, corrosion and vibration may be present, or NEMA 3 and 4 areas where wind, water, snow or high ambients can be expected. VSL's are sized to replace "Utility" type fixtures (incandescent or CFL's) in hallways, closets, elevator pits, docks, stairwells, access tunnels, and mechanical rooms. These fixtures can be used in locations made hazardous by the presence of flammable vapors or gases or combustible dusts as defined by the NEC. Typical applications include manufacturing plants, and certain chemical and petrochemical processing facilities, sewage treatment plants, off-shore and dockside installations, and garage areas.

LED Luminaire Features and Standards

- Compact in Size with Traditional Industrial Appearance and Suitability
- Wide variety of optics including glass globes (clear and tempered, color) plus polycarbonate globes in clear and colors
- Optional Mounting arrangements including Pendant, Wall, Ceiling, Stanchion and Adapters
- Fixtures available unit packed, order option CP
- VSL LED Housings can be retrofitted to existing V Series splice boxes; upgrade from CFL or incandescent
- Energy Savings - less than 13 Watts of Power; less than 16 Watts for VSL1630. Replaces 75W or higher incandescent
- Long Life - 60,500+ maintenance-free hours to 70% initial lumens
- Crisp White Light for Excellent Color Rendering - Chromaticity 5000°K (CCT); 70 CRI
- Integral driver - maintains fixture's compact profile to fit in existing spaces
- Ambient suitability -40°C to 55°C^②

- Instant on - including after power interruption
- "World Voltage" 120-277VAC 50/60Hz
- Solder-LESS LED Board Connections – Vibration Resistant
- LM80-08* Measurement of lumen maintenance for LED light sources
- LM79-08* Certified "Absolute" Photometry, including Chromaticity Color for Solid State Lighting
- TM-21* method to project long term lumen maintenance
- L70 Values - Industry Nomenclature for Hours of use to 70% of Initial Lumens

Compliances

- UL-8750 for LED lighting
- UL 1598 standard for luminaires
- UL-844 Standard for lighting fixtures for hazardous locations, Class I, Division 2; Class II, Division 2; Class III, Division 2
- CSA C22.2 no. 137-M1981 electric luminaires for use in hazardous locations
- Enclosed and gasketed
- NEMA 3, 4

Materials

- Body, splice box and guards are corrosion resistant copper-free aluminum alloy
- Baked powder epoxy/polyester finish, electrostatically applied for complete, uniform corrosion protection
- Reflectors - Polypropylene for pendant or ceiling applications
- Heavy-duty silicone gasketing for NEMA 4 requirements

* LM-xx & TM-21 are Illumination Engineering Society Standards designed to promote uniformity in testing procedures among test labs and manufacturers. For more information go to www.ies.org

① When mounted (globe down) to V series boxes; not Class II, Div. 2 or NEMA 4 on VBA, VFPS, VB or VFL adaptors to sheet metal boxes.

② Glass globe models to 55°C; Polycarbonate suitable to 40°C.

Optic Selection Examples

- Broadest **COLOR** globe offering for Hazardous Locations in the industry
- Use as status lights or specialty/emergency indicators



KILLARK



Clear Glass w/Guard

White Glass w/Guard

Blue Glass

Clear Polycarbonate

Red Polycarbonate

Class I, Div. 2, Groups A,B,C,D
Class I, Zone 2, Groups IIC,IIB,IIA
Class II, Div. 2, Groups F,G^①
Class III
Suitable for wet locations
Enclosure Type 4^①

US Certified - File LR11713

V SERIES LED Catalog Number Logic

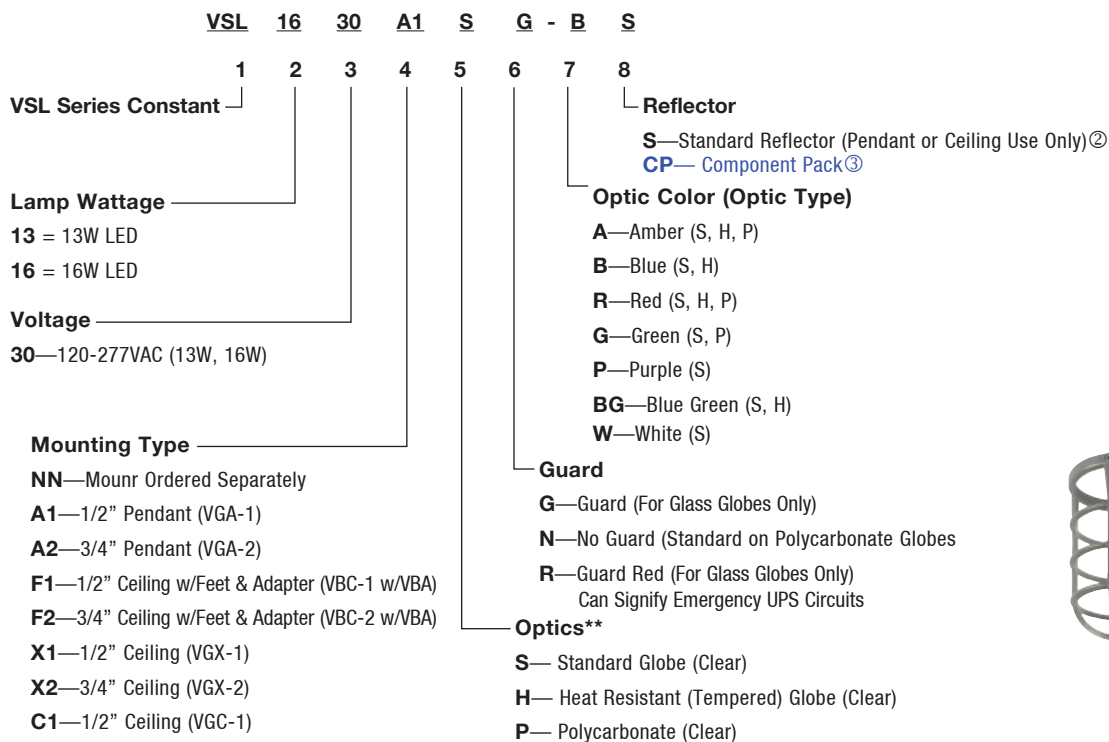

- Mounting Type**
- NN—Mounr Ordered Separately
 - A1—1/2" Pendant (VGA-1)
 - A2—3/4" Pendant (VGA-2)
 - F1—1/2" Ceiling w/Feet & Adapter (VBC-1 w/VBA)
 - F2—3/4" Ceiling w/Feet & Adapter (VBC-2 w/VBA)
 - X1—1/2" Ceiling (VGX-1)
 - X2—3/4" Ceiling (VGX-2)
 - C1—1/2" Ceiling (VGC-1)
 - C2—3/4" Ceiling (VGC-2)
 - H1—1/2" Ceiling Dead End (VGH-1)
 - H2—3/4" Ceiling Dead End (VGH-2)
 - D1—1/2" Ceiling Deep (VXA-1)
 - D2—3/4" Ceiling Deep (VXA-2)
 - D4—1-1/4" Stanchion (VD-4)
 - RA—Round (Box) Adapter (VBA)
 - SA—Square (Box) Adapter (VFPS)
 - W1—1/2" Wall w/Feet (VBC-1 w/VB-1)
 - W2—3/4" Wall w/Feet (VBC-2 w/VB-2)
 - V1—1/2" Wall Elbow (VB-1)
 - V2—3/4" Wall Elbow (VB-2)
 - FL—Elbow for "V" Box (VFL)

COLORED GLOBE OPTIONS** Example VSL1330A1SG-A

SUFFIX AND AVAILABLE COMBINATIONS			
COLOR NUMBER	STANDARD GLOBE	TEMPERED GLOBE	POLYCARBONATE
Amber	A	A	A
Blue	B	B	—
Ruby	R	R	R
Green	G	—	G
Purple	P	—	—
Blue-Green	BG	BG	—
White	W	W	W



** Use tempered glass or poly globe for wet location applications.
^① When mounted (globe down) to V series boxes; not Class II, Div.2 or NEMA 4 on VBA, VFPS, VB or VFL adaptors to sheet metal boxes.
^② Reflector is held on fixture body by VAG-100 guard for glass globe models or polycarbonate globe's shoulder. Reflectors ship separately.
^③ CP option includes complete fixture in components contained in single outer carton.



Class I, Div. 2, Groups A,B,C,D
Class I, Zone 2, Groups IIC,IIB,IIA
Class II, Div. 2, Groups F,GⓈ
Class III
Suitable for wet locations
Enclosure Type 4Ⓢ

Certified - File LR11713

ORDERING INFORMATION



PENDANT MOUNT WITH VGA SPLICE BOX 1 - HUB						
LED	Watts	Voltage	Hub Size	Fixture w/Standard Clear Glass Globe & Guard **	Fixture w/Tempered Clear Glass Globe & Guard **	Fixture w/Clear Polycarbonate Globe **
VSL1330	13	120-277VAC	1/2"	VSL1330A1SG	VSL1330A1HG	VSL1330A1PN
			3/4"	VSL1330A2SG	VSL1330A2HG	VSL1330A2PN
VSL1630	16	120-277VAC	1/2"	VSL1630A1SG	VSL1630A1HG	VSL1630A1PN
			3/4"	VSL1630A2SG	VSL1630A2HG	VSL1630A2PN



CEILING MOUNT WITH FEET USING VBC SPLICE BOX AND VBA ADAPTER 4 - HUBS						
LED	Watts	Voltage	Hub Size	Fixture w/Standard Clear Glass Globe & Guard **	Fixture w/Tempered Clear Glass Globe & Guard **	Fixture w/Clear Polycarbonate Globe **
VSL1330	13	120-277VAC	1/2"	VSL1330F1SG	VSL1330F1HG	VSL1330F1PN
			3/4"	VSL1330F2SG	VSL1330F2HG	VSL1330F2PN
VSL1630	16	120-277VAC	1/2"	VSL1630F1SG	VSL1630F1HG	VSL1630F1PN
			3/4"	VSL1630F2SG	VSL1630F2HG	VSL1630F2PN



CEILING MOUNT WITH VGX SPLICE BOX 4 - HUBS						
LED	Watts	Voltage	Hub Size	Fixture w/Standard Clear Glass Globe & Guard **	Fixture w/Tempered Clear Glass Globe & Guard **	Fixture w/Clear Polycarbonate Globe **
VSL1330	13	120-277VAC	1/2"	VSL1330X1SG	VSL1330X1HG	VSL1330X1PN
			3/4"	VSL1330X2SG	VSL1330X2HG	VSL1330X2PN
VSL1630	16	120-277VAC	1/2"	VSL1630X1SG	VSL1630X1HG	VSL1630X1PN
			3/4"	VSL1630X2SG	VSL1630X2HG	VSL1630X2PN



CEILING MOUNT WITH VGC SPLICE BOX - FEED THROUGH 2 - HUBS						
LED	Watts	Voltage	Hub Size	Fixture w/Standard Clear Glass Globe & Guard **	Fixture w/Tempered Clear Glass Globe & Guard **	Fixture w/Clear Polycarbonate Globe **
VSL1330	13	120-277VAC	1/2"	VSL1330C1SG	VSL1330C1HG	VSL1330C1PN
			3/4"	VSL1330C2SG	VSL1330C2HG	VSL1330C2PN
VSL1630	16	120-277VAC	1/2"	VSL1630C1SG	VSL1630C1HG	VSL1630C1PN
			3/4"	VSL1630C2SG	VSL1630C2HG	VSL1630C2PN

Ⓢ When mounted (globe down) to V series boxes; not Class II, Div.2 or NEMA 4 on VBA, VFPS, VB or VFL adaptors to sheet metal boxes.
** Use tempered glass or poly globes for wet location applications. See logic page for available globe colors.



Class I, Div. 2, Groups A,B,C,D
Class I, Zone 2, Groups IIC,IIB,IIA
Class II, Div. 2, Groups F,G⓪
Class III
Suitable for wet locations
Enclosure Type 4⓪

Certified - File LR11713

ORDERING INFORMATION



CEILING MOUNT WITH VGH SPLICE BOX - DEAD END 1 - HUB						
LED	Watts	Voltage	Hub Size	Fixture w/Standard Clear Glass Globe & Guard **	Fixture w/Tempered Clear Glass Globe & Guard **	Fixture w/Clear Polycarbonate Globe **
VSL1330	13	120-277VAC	1/2"	VSL1330H1SG	VSL1330H1HG	VSL1330H1PN
			3/4"	VSL1330H2SG	VSL1330H2HG	VSL1330H2PN
VSL1630	16	120-277VAC	1/2"	VSL1630H1SG	VSL1630H1HG	VSL1630H1PN
			3/4"	VSL1630H2SG	VSL1630H2HG	VSL1630H2PN



CEILING MOUNT WITH VXA DEEP SPLICE BOX 5 - HUBS						
LED	Watts	Voltage	Hub Size	Fixture w/Standard Clear Glass Globe & Guard **	Fixture w/Tempered Clear Glass Globe & Guard **	Fixture w/Clear Polycarbonate Globe **
VSL1330	13	120-277VAC	1/2"	VSL1330D1SG	VSL1330D1HG	VSL1330D1PN
			3/4"	VSL1330D2SG	VSL1330D2HG	VSL1330D2PN
VSL1630	16	120-277VAC	1/2"	VSL1630D1SG	VSL1630D1HG	VSL1630D1PN
			3/4"	VSL1630D2SG	VSL1630D2HG	VSL1630D2PN



CEILING MOUNT WITH VBA ADAPTER FOR ROUND OUTLET BOX 0 - HUBS ⓪						
LED	Watts	Voltage	Hub Size	Fixture w/Standard Clear Glass Globe & Guard **	Fixture w/Tempered Clear Glass Globe & Guard **	Fixture w/Clear Polycarbonate Globe **
VSL1330	13	120-277VAC	-	VSL1330RASG	VSL1330RAHG	VSL1330RAPN
VSL1630	16	120-277VAC	-	VSL1630RASG	VSL1630RAHG	VSL1630RAPN



CEILING MOUNT WITH VFPS ADAPTER FOR SQUARE OR OCTAGON OUTLET BOX 0 - HUBS ⓪						
LED	Watts	Voltage	Hub Size	Fixture w/Standard Clear Glass Globe & Guard **	Fixture w/Tempered Clear Glass Globe & Guard **	Fixture w/Clear Polycarbonate Globe **
VSL1330	13	120-277VAC	-	VSL1330SASG	VSL1330SAHG	VSL1330SAPN
VSL1630	16	120-277VAC	-	VSL1630SASG	VSL1630SAHG	VSL1630SAPN

⓪ When mounted (globe down) to V series boxes; not Class II, Div.2 or NEMA 4 on VBA, VFPS, VB or VFL adaptors to sheet metal boxes.
** Use tempered glass or poly globes for wet location applications. See logic page for available globe colors.



Class I, Div. 2, Groups A,B,C,D
Class I, Zone 2, Groups IIC,IIB,IIA
Class II, Div. 2, Groups F,G⓪
Class III
Suitable for wet locations
Enclosure Type 4⓪

Certified - File LR11713

ORDERING INFORMATION



WALL MOUNT WITH FEET USING VBC SPLICE BOX AND VB ELBOW 4 - HUBS						
LED	Watts	Voltage	Hub Size	Fixture w/Standard Clear Glass Globe & Guard **	Fixture w/Tempered Clear Glass Globe & Guard **	Fixture w/Clear Polycarbonate Globe **
VSL1330	13	120-277VAC	1/2"	VSL1330W1SG	VSL1330W1HG	VSL1330W1PN
			3/4"	VSL1330W2SG	VSL1330W2HG	VSL1330W2PN
VSL1630	16	120-277VAC	1/2"	VSL1630W1SG	VSL1630W1HG	VSL1630W1PN
			3/4"	VSL1630W2SG	VSL1630W2HG	VSL1630W2PN



WALL MOUNT WITH VB ELBOW TO MOUNT TO 4" OUTLET BOX 0 - HUBS⓪						
LED	Watts	Voltage	Neck Hub Size	Fixture w/Standard Clear Glass globe & Guard **	Fixture w/Tempered Clear Glass globe & Guard **	Fixture w/Clear Polycarbonate Globe **
VSL1330	13	120-277VAC	1/2"	VSL1330V1SG	VSL1330V1HG	VSL1330V1PN
			3/4"	VSL1330V2SG	VSL1330V2HG	VSL1330V2PN
VSL1630	16	120-277VAC	1/2"	VSL1630V1SG	VSL1630V1HG	VSL1630V1PN
			3/4"	VSL1630V2SG	VSL1630V2HG	VSL1630V2PN

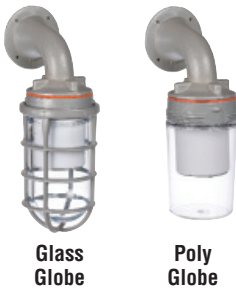

WALL MOUNT-WITH VFL ELBOW FOR DIRECT MOUNT TO V SERIES SPLICE BOXES 0 - HUBS⓪						
LED	Watts	Voltage	Hub Size	Fixture w/Standard Clear Glass Globe & Guard **	Fixture w/Tempered Clear Glass Globe & Guard **	Fixture w/Clear Polycarbonate Globe **
VSL1330	13	120-277VAC	-	VSL1330FLSG	VSL1330FLHG	VSL1330FLPN
VSL1630	16	120-277VAC	-	VSL1630FLSG	VSL1630FLHG	VSL1630FLPN



STANCHION MOUNT FOR 1 - 1 / 4" THREADED PIPE 1 - HUB						
LED	Watts	Voltage	Hub Size	Fixture w/Standard Clear Glass Globe & Guard **	Fixture w/Tempered Clear Glass Globe & Guard **	Fixture w/Clear Polycarbonate Globe **
VSL1330	13	120-277VAC	1-1/4"	VSL1330D4SG	VSL1330D4HG	VSL1330D4PN
VSL1630	16	120-277VAC	1-1/4"	VSL1630D4SG	VSL1630D4HG	VSL1630D4PN

⓪ When mounted (globe down) to V series boxes; not Class II, Div.2 or NEMA 4 on VBA, VFPS, VB or VFL adaptors to sheet metal boxes.
** Use tempered glass or poly globes for wet location applications. See logic page for available globe colors.



VSL Body

**RETROFIT
FOR ENERGY
SAVINGS**

VSL Fixture Bodies Only

Fixture bodies contain the LED driver and array, heat sink plus gaskets, and are threaded to accept globes, guards and reflectors. Users with KILLARK "V" Series vapor tight fixtures from the 1960's onward can upgrade to the latest technology and, in many cases, reuse existing mounts, globes and guards. VSL bodies are designed for metallic boxes and mount directly to V Series splice boxes or adapters as indicated.

VSL FIXTURE BODIES	
CATALOG NUMBER	DESCRIPTION
VSL1330	13W 120-277VAC 50/60Hz Body with LEDs and Driver
VSL1630	16W 120-277VAC 50/60Hz Body with LEDs and Driver



VGA



VGH

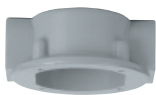

VGC



VGX



VXA



VBC

VSL Splice Boxes

For use with VSL Series fixture bodies.

VSL SPLICE BOXES				
CATALOG NUMBER	HUB SIZE	QTY.	LOGIC CODE	DESCRIPTION
VGA-1	1/2"	1	A1	Pendant mount
VGA-2	3/4"	1	A2	
VGH-1	1/2"	1	H1	Ceiling mount
VGH-2	3/4"	1	H2	
VGC-1	1/2"	2	C1	Ceiling mount
VGC-2	3/4"	2	C2	
VGX-1	1/2"	4	X1	Ceiling mount
VGX-2	3/4"	4	X2	
VXA-1	1/2"	5	D1	Ceiling mount, deep box
VXA-2	3/4"	5	D2	
VBC-1*	1/2"	4	F1	Ceiling mount, with 3 close-up plugs (requires VBA Adapter) or wall mount with VB elbow
VBC-2*	3/4"	4	F2	
VXAB	—	—	—	Blank close-up plate (less gasket)

*Volume cu. in. is 18

VSL Adapters

VSL ADAPTER MOUNTING PLATES	
CATALOG NUMBER	DESCRIPTION
VBA	Adapts fixture body to VB, VJ or steel 3-1/2" & 4" splice boxes. Supplied with gasket.
VFPS	Adapts fixture body to steel 4" square outlet boxes or 3-1/2" or 4" octagon boxes



VBA



VFPS

VSL Wall/Stanchion Mounts

VSL MOUNTING BRACKETS			
CATALOG NUMBER	HUB SIZE	QTY.	DESCRIPTION
VB-1	1/2"	1	Wall mount to VJ or VB boxes
VB-2	3/4"	1	Wall mount to VJ or VB boxes
VFL	—	—	Wall mount to V boxes directly or to VJ, VB boxes with VBA adapter
VD-4	1-1/4"	1	Stanchion mount



VB



VFL



VD





Glass
Globe



Glass Color
Globe



Poly
Globe



Poly Color
Globe

VSL Globes

VSL GLOBES - ORDERING INFORMATION AND SUFFIX GRID**						
COLOR	GLASS	OPTIC LOGIC	TEMPERED GLASS	OPTIC LOGIC	POLYCARBONATE	OPTIC LOGIC
Clear	VCG-100	S*	VCGP-100	H*	VPLCG-100	P*
Amber	VAMG-100	A	VAMGP-100	A	VPLCG-100A	A
Blue	VBG-100	B	VBGP-100	B	—	—
Ruby (Red)	VRG-100	R	VRGP-100	R	VPLCG-100R	R
Green	VRSG-100	G	—	—	VPLCG-100G	G
Purple	VPG-100	P	—	—	—	—
Blue-Green	VGG-100	BG	VGGP-100	BG	—	—
White	VWG-100	W	VWGP-100	W	VPLCG-100W	W

* See Pre-configured ordering tables for complete fixtures.

** Use tempered glass or polycarbonate globes for wet location applications.



VAG-100



VTG-S



VTGG1-S



VPRSD-100
16-3/8" Dia. 5-5/8" High

VSL Components

VSL COMPONENT PARTS AND ACCESSORIES	
CATALOG NUMBER	DESCRIPTION
VAG-100	Aluminum Guard for use with Glass Globe
VAG-100R	Red Aluminum Guard for use with Glass Globe
VTG-S	Body to Splice Box Gasket - Silicone
VTGG1-S	Globe Gasket - Silicone
VPRSD-100	White polypropylene for pendant & ceiling applications. Not for use with wall or stanchion models.

VSL Thermal Ratings

VSL THERMAL PERFORMANCE DATA INCLUDING VPRSD-100 REFLECTOR								
CATALOG NUMBER	AMBIENT	C1D2		C2D2		SUPPLY WIRE	L70 ^③	
		GLASS GLOBE	POLY GLOBE	GLASS GLOBE	POLY GLOBE		TM-21	CALCULATED
VSL1330	40°C	T6	T5	T5 (F,G)	T5 (F,G)	90°	60,500	100,000+
VSL1330	55°C	T5	—	—	—	90°	60,500	100,000+
VSL1630	40°C	T5	—	T5 (F,G)	—	90°	60,500	100,000+

VSL Electrical Ratings

VSL LED BODY WITH DRIVERS ^① AND LEDS - ELECTRICAL RATINGS					
CATALOG NUMBER	VOLTAGE 50/60HZ	WATTAGE	AMPS 120/277	CIL ^②	WEIGHT LBS.
VSL1330	120-277VAC	12.42	.108/.047	1300	5.0
VSL1630	120-277VAC	15.64	.156/.067	1625	5.0

① Driver THD<20%, Powerfactor >90% @ 120V; Line regulation 2%; Load regulation 5%; Protected against Over-voltage and Overcurrent.

② CIL = Calculated Initial Lumens of LED component based on mfg. data and driver current INSIDE the optic. This value is provided as a reference only for comparison to traditional light sources such as Incandescent, HID, or fluorescent which use initial values in "relative" photometry. KILLARK LED luminaires are tested using the Absolute photometry method (LM79-08), which calculates delivered lumens only. KILLARK's LED luminaires provide very bright white 5000° K (CCT) color and can appear brighter than traditional light sources with higher lumen values under both photopic and scotopic conditions.

③ "TM-21 based values require very long duration testing. The L70/TM-21 "official reported" value is based on 10,000 hours testing at 1000mA drive current ("reported L70" is a factor of test duration). KILLARK's VSL utilizes lower 450mA maximum drive current - "calculated" values by the chip vendor predict L70 life substantially in excess of 100,000 hours even at 1000mA."



LED 13 Watt Clear Glass Globe VCG-100

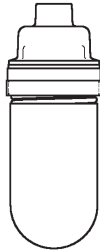

ZONE	LUMENS	%LAMP	%FIXT
0- 30	243. NA.	21.6	
0- 40	393. NA.	35.1	
0- 60	802. NA.	71.5	
0- 90	1095. NA.	97.7	
90-120	16. NA.	1.5	
90-130	21. NA.	1.9	
90-150	25. NA.	2.2	
90-180	25. NA.	2.3	
0-180	1121	NA.	100.0

Absolute Photometry
Total Luminaire Efficiency = NA.%
Spacing to Mounting Height Ratio .9

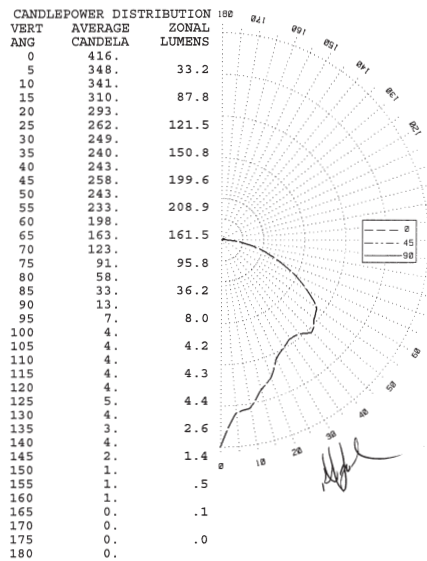

LED 16 Watt Clear Glass Globe VCG-100



ZONE	LUMENS	%LAMP	%FIXT
0- 30	310 NA.	23.3	
0- 40	478 NA.	36.0	
0- 60	959 NA.	72.2	
0- 90	1307 NA.	98.4	
90-120	12 NA.	.9	
90-130	16 NA.	1.2	
90-150	21 NA.	1.6	
90-180	21 NA.	1.6	
0-180	1328	NA.	100.0

Absolute Photometry
Total Luminaire Efficiency = NA.%
Spacing to Mounting Height Ratio 1.1

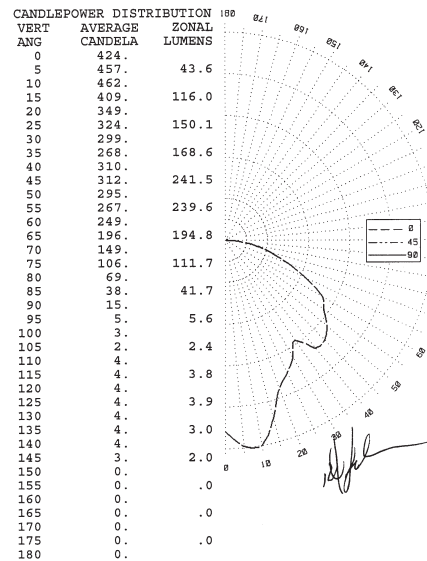

LED 13 Watt White Glass Globe VWG-100



ZONE	LUMENS	%LAMP	%FIXT
0- 30	63 NA.	6.9	
0- 40	117 NA.	12.9	
0- 60	272 NA.	30.1	
0- 90	561 NA.	62.0	
90-120	233 NA.	25.7	
90-130	282 NA.	31.2	
90-150	333 NA.	36.8	
90-180	344 NA.	38.0	
0-180	905	NA.	100.0

Absolute Photometry
Total Luminaire Efficiency = NA.%
Spacing to Mounting Height Ratio 2.0

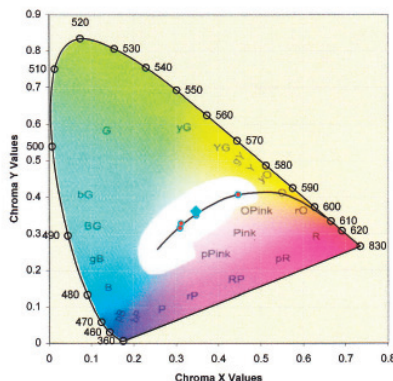
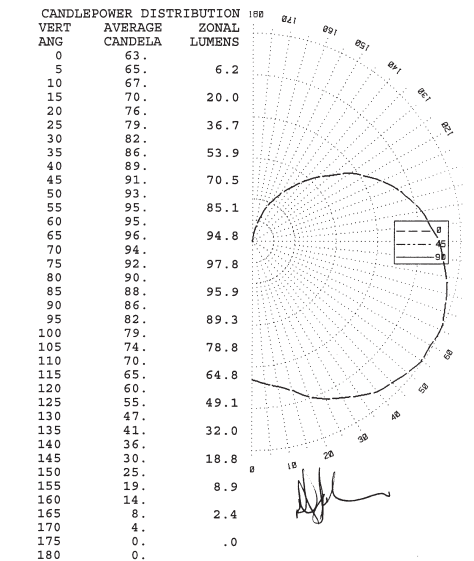

Chromaticity 4927.2°K(CCT); 73.1 CRI
Certified Report BAL16352.0

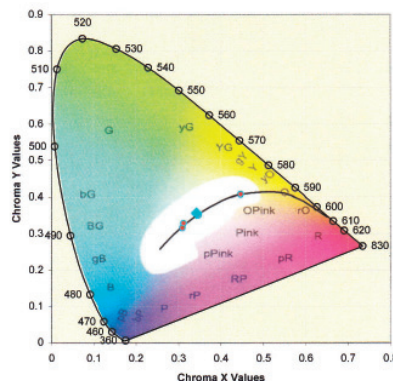

Chromaticity 5054.5°K(CCT); 75.3 CRI
Certified Report BAL16350.0

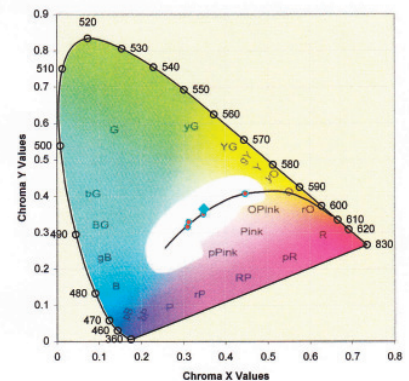

Chromaticity 4897.0°K(CCT); 72.4 CRI
Certified Report BAL16366.0

LED 13 Watt Clear Glass Globe and Reflector

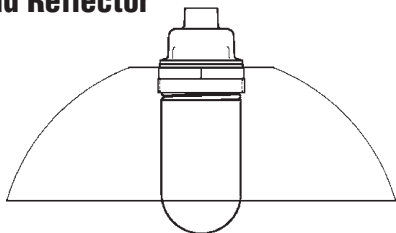

ZONE	LUMENS	%LAMP	%FIXT
0- 30	265 NA.	24.1	
0- 40	437 NA.	39.6	
0- 60	879 NA.	79.8	
0- 90	1097 NA.	99.5	
90-120	3 NA.	.3	
90-130	4 NA.	.4	
90-150	5 NA.	.5	
90-180	6 NA.	.5	
0-180	1102 NA.	100.0	

Absolute Photometry
Total Luminaire Efficiency = NA.%
Spacing to Mounting Height Ratio .9

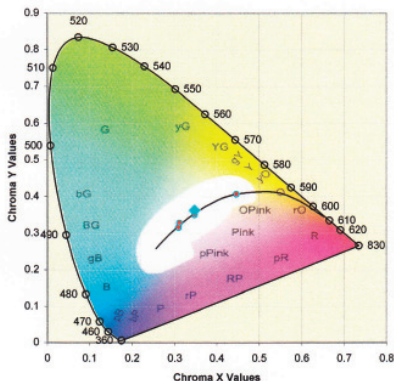
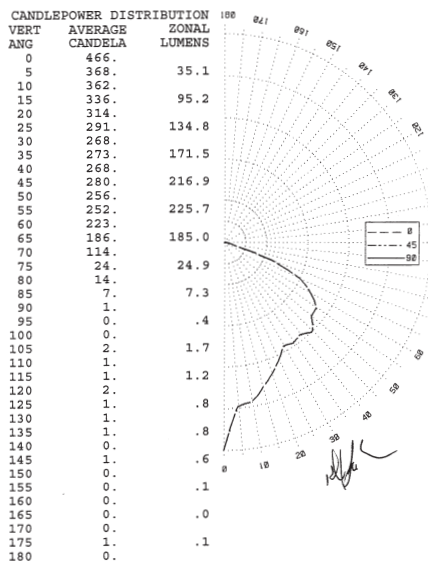

Chromaticity 4913.5°K(CCT); 72.9 CRI
Certified Report BAL16353.0

LED 13 Watt Clear Poly Globe VPLCG-100



ZONE	LUMENS	%LAMP	%FIXT
0- 30	225 NA.	20.4	
0- 40	396 NA.	35.8	
0- 60	780 NA.	70.6	
0- 90	1076 NA.	97.4	
90-120	11 NA.	1.0	
90-130	14 NA.	1.3	
90-150	22 NA.	2.0	
90-180	28 NA.	2.6	
0-180	1104 NA.	100.0	

Absolute Photometry
Total Luminaire Efficiency = NA.%
Spacing to Mounting Height Ratio 1.3

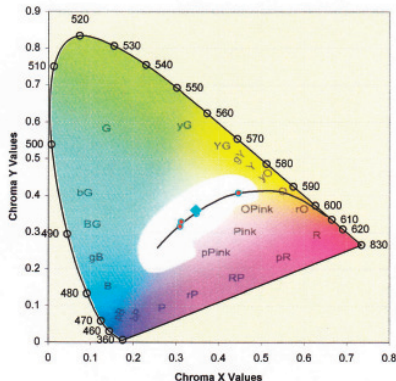
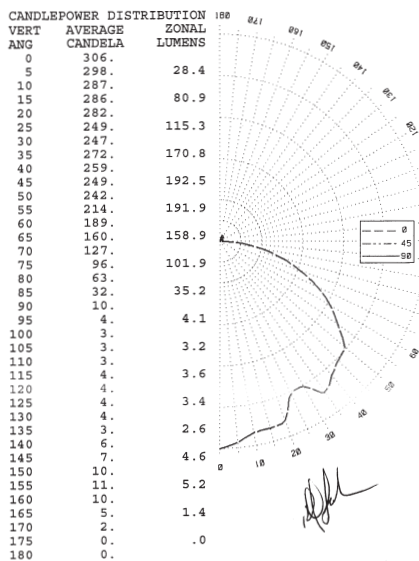

Chromaticity 4954.8°K(CCT); 73.9 CRI
Certified Report BAL16364.0

LED 13 Watt Clear Poly Globe and Reflector

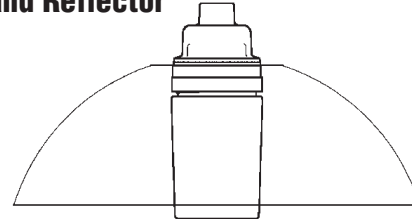

ZONE	LUMENS	%LAMP	%FIXT
0- 30	256 NA.	23.3	
0- 40	443 NA.	40.4	
0- 60	875 NA.	79.8	
0- 90	1092 NA.	99.7	
90-120	1 NA.	.1	
90-130	2 NA.	.2	
90-150	3 NA.	.3	
90-180	4 NA.	.3	
0-180	1096 NA.	100.0	

Absolute Photometry
Total Luminaire Efficiency = NA.%
Spacing to Mounting Height Ratio 1.3

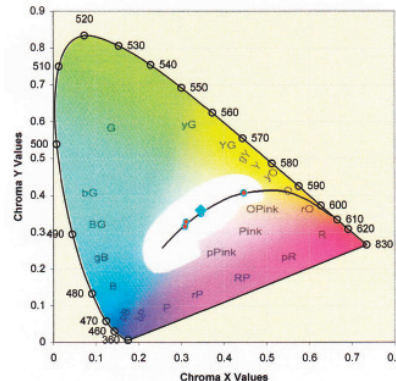
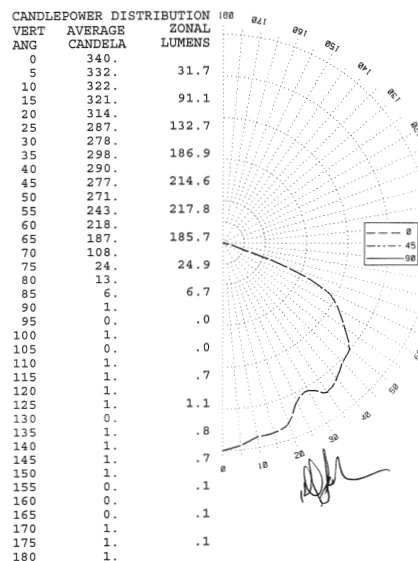

Chromaticity 4937.7°K(CCT); 73.9 CRI
Certified Report BAL16365.0



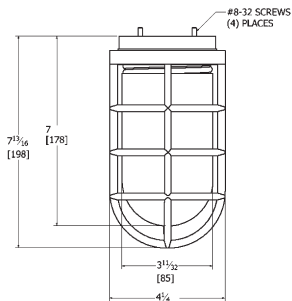

**VSL Body w/Globe & Guard,
No Splice Box**

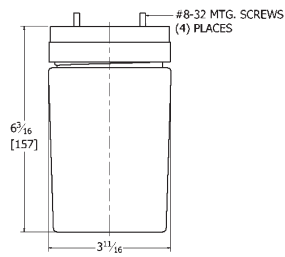

**VSL Body
w/Polycarbonate Globe,
No Splice Box**

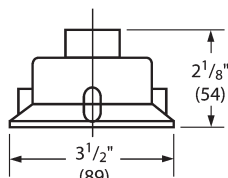

VGA

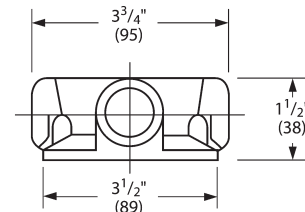

**VGC or VGX
*VGH is 3-5/8" (92)**

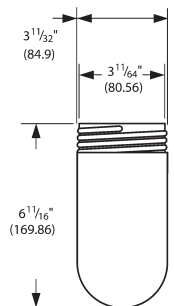

Glass Globe

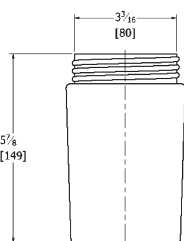

Polycarbonate Globe

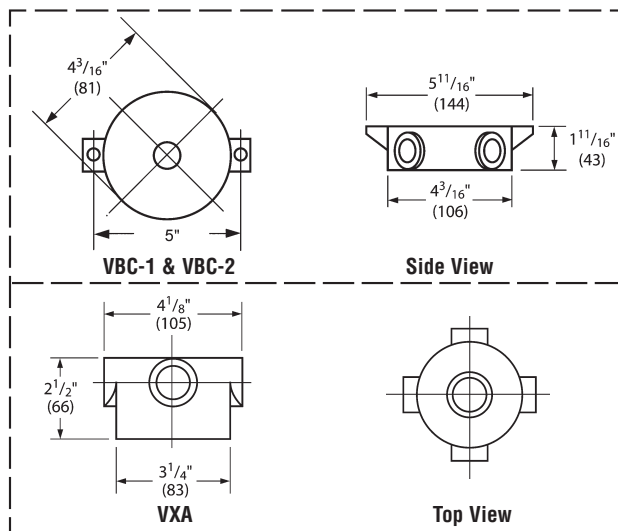

VBC-1 & VBC-2

Side View

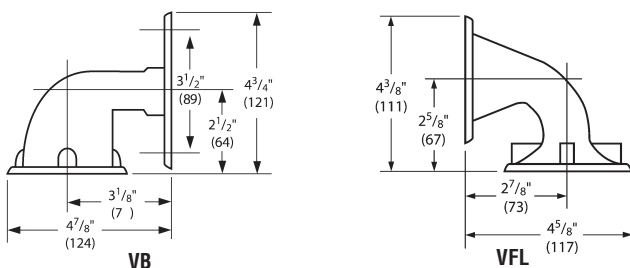

VXA

Top View

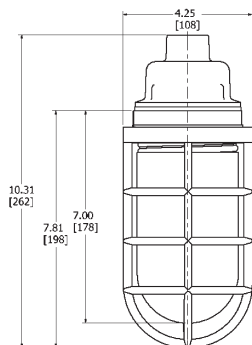

**VSL Pendant Fixture
w/Globe & Guard**

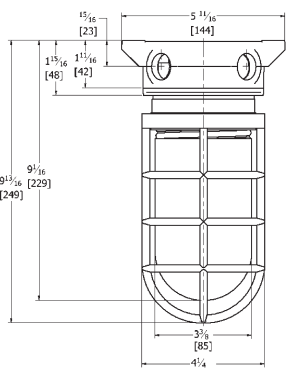

**VSL Ceiling Fixture
w/Globe & Guard**

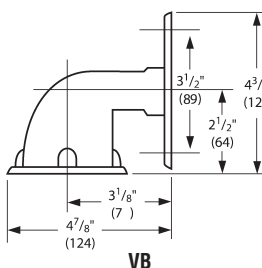

VB

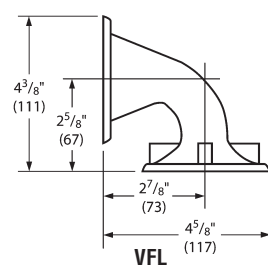

VFL

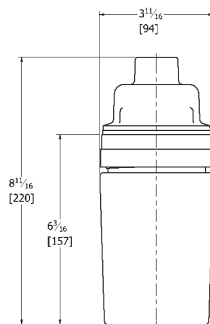

**VSL Pendant Fixture
w/Polycarbonate Globe**

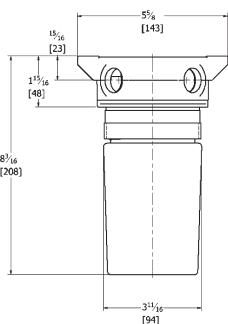

**VSL Ceiling Fixture
w/Polycarbonate Globe**

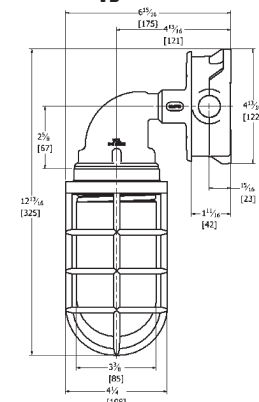

**VSL Wall Mounted Fixture
w/Globe & Guard**

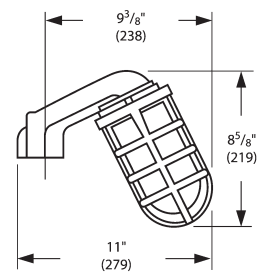

**VSL Stanchion Fixture
w/Globe & Guard**

